

## CONTROL VALVE APPLICATION TECHNOLOGY

Techniques and considerations for properly  
selecting the right control valve

# Contents

|          |  |            |
|----------|--|------------|
| <b>1</b> | <b>Control Valve Overview</b>  | <b>1</b>   |
| <b>2</b> | <b>Effect of Flow Characteristic and Valve Sizing on Controllability</b> | <b>17</b>  |
| <b>3</b> | <b>Introduction to Noise Terminology</b>                                 | <b>32</b>  |
| <b>4</b> | <b>Liquid Flow in Control Valves</b>                                     | <b>36</b>  |
| <b>5</b> | <b>Gas Flow in Control Valves</b>  | <b>60</b>  |
| <b>6</b> | <b>Control Valves and Process Variability</b>                            | <b>85</b>  |
| <b>7</b> | <b>Installed Gain as a Valve Sizing Criterion</b>                        | <b>102</b> |
| <b>8</b> | <b>Control Valve Sizing</b>  | <b>119</b> |

When the elliptical disc closes into the round seat, the seat is stretched like a rubber band to give a very tight mechanical seal.

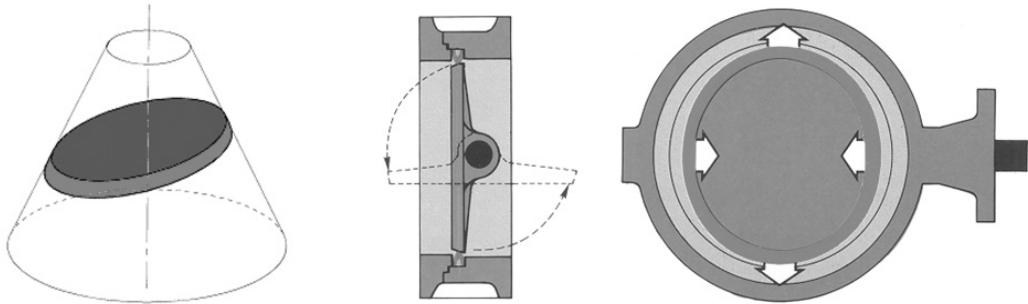

**Figure 1-14. The third offset of a metal seated high performance butterfly valve. (Courtesy of Metso Automation)**

### *Control Valve Selection*

If one control valve type was the best for all applications, then everyone would only make that one type of valve.

In the old days it was easy to decide what type of valve to use. Now that everyone must be more competitive and watch expenses, we need to take a close look at all aspects of an application and choose the most appropriate valve.

#### **OLD METHOD**

**Use the same type valve we always have.**

#### **NEW METHOD**

**Select the best valve type for each application considering:**

- **Operating temperature and pressure**
- **Cost**
- **Weight**
- **Flow characteristic**
- **Cavitation potential**
- **Stem sealing**

## Cost

Everyone is concerned with cost. The graph shown in Figure 1-18 is pretty much self explanatory. Not so obvious, however is the fact that the rotary valves have greater capacity size for size. For example, it is possible that an application which requires a 10 inch globe valve may be able to use an 8 inch segment ball or butterfly valve, making the savings even more dramatic.



Figure 1-18. Comparison of approximate costs for High Performance butterfly valves, segment ball valves, eccentric rotary plug valves and globe valves.

## Weight

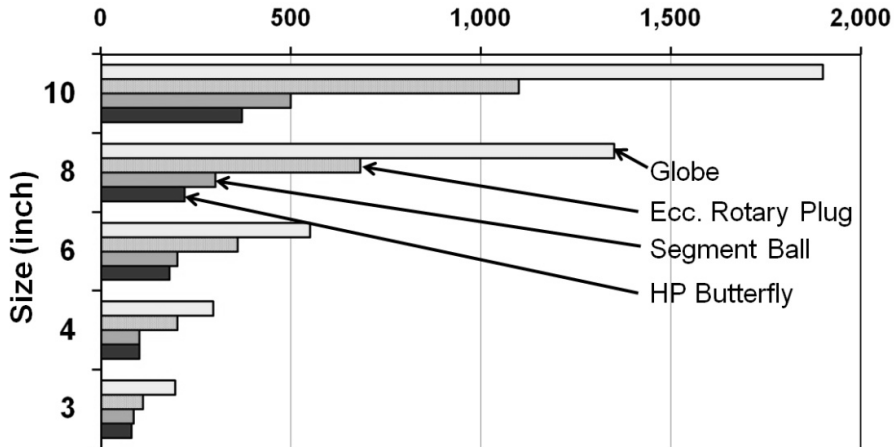

Figure 1-19. Comparison of approximate weights of High Performance butterfly valves, segment ball valves, eccentric rotary plug valves and globe valves.

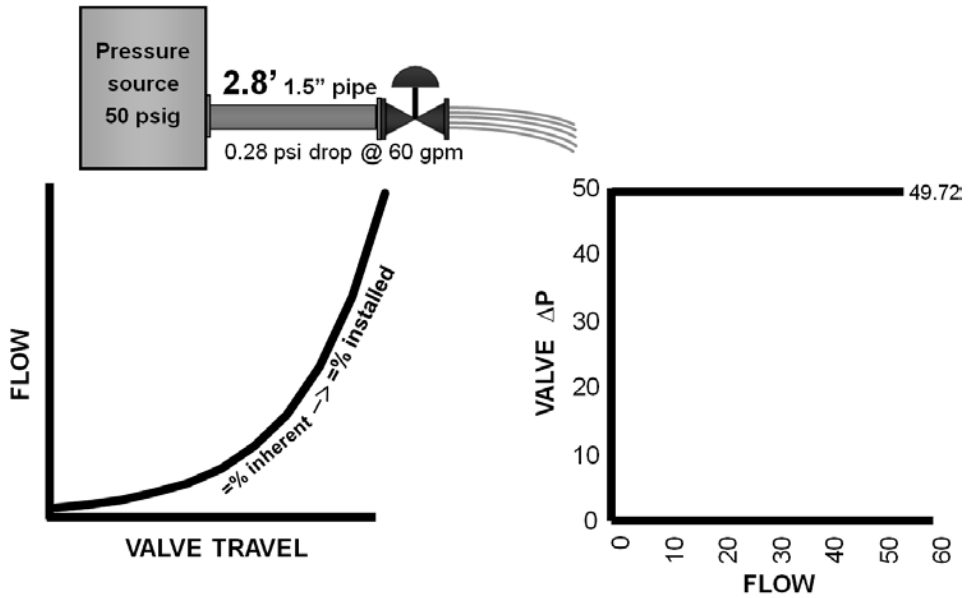

Figure 2-7. This is a misapplied equal percentage valve. In a system with very little pipe, an equal percentage valve will have a nonlinear installed characteristic.

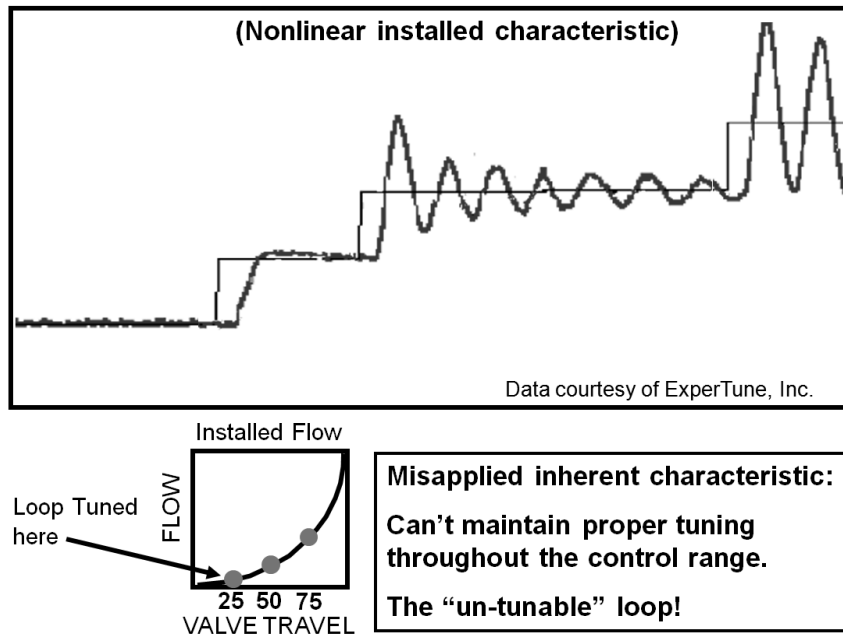

Figure 2-8. A nonlinear installed characteristic results in a system that is difficult to tune for good control and stability throughout the required flow range.

When a valve with the wrong inherent characteristic is put in a system, its installed characteristic will be non-linear, as shown in the small graph of Figure 2-8. If the loop were tuned when the system was running at a control valve opening of 25%, and where the valve is fairly insensitive to changes in controller output, a high value of proportional gain would be required to get good response. When system demand increases to where the control valve is 50% open, the valve is more sensitive to changes in controller output and as a result the tuning parameters selected at a valve opening of 25% are too aggressive and a step change in set point results in an unstable response. When the system demand results in a control valve opening of 75%, the valve is very sensitive to changes in travel and the situation is even worse and a set point change results in an extremely oscillatory response.

If instead, the loop were tuned when the control valve was 75% open, a lower value of proportional gain would have been used, and we would get fast stable response to a step change in set point, but if we then operated at lower loads, the response would be very sluggish.

If we had misapplied a linear valve in a system with a lot of pipe the situation would be the opposite of what is shown here. Just as the system with a lot of pipe pushes the equal percentage inherent characteristic upward into a linear installed characteristic, it would push a linear inherent characteristic upward into a quick opening characteristic. Now we would have a system that would be very sensitive at low valve openings and very insensitive at large openings. The system would still be difficult or impossible to tune so as to get fast stable response throughout the flow range.

We previously saw in Figures 2-5 and 2-6 examples of properly applied inherent flow characteristics. That is, a linear valve in a system with very little pipe and an equal percentage valve in a system with a lot of pipe. Both have a linear or very nearly linear installed characteristic.

We just saw why a nonlinear installed characteristic is bad. Next we will see why a linear installed characteristic is good.

In Figure 2-9 we have a linear (or at least nearly so) installed characteristic. Since the sensitivity of this system to changes in valve position remains nearly constant, the same set of controller tuning parameters will give fast response with stability throughout the control range.

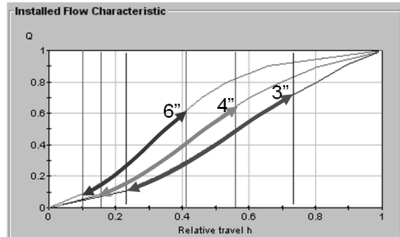
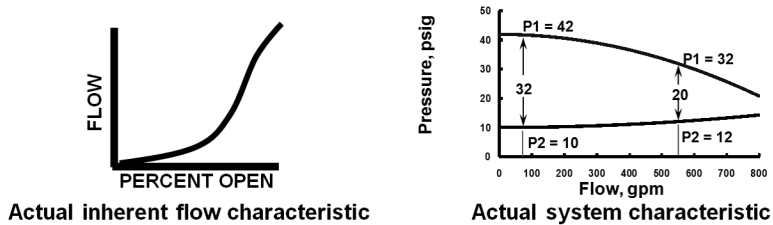

Installed characteristic of the exact valve being considered in the exact system it will be installed in.

**Figure 2-11.** An example of how the Nelprof software can graph the installed characteristic of a control valve based on its inherent flow characteristic and the pressure vs. flow behavior of the system.

### *Linearizing the Installed flow Characteristic*

If the installed characteristic deviates significantly from linear, the nonlinearity can be removed by programming a modification curve into either the DCS or a digital positioner.

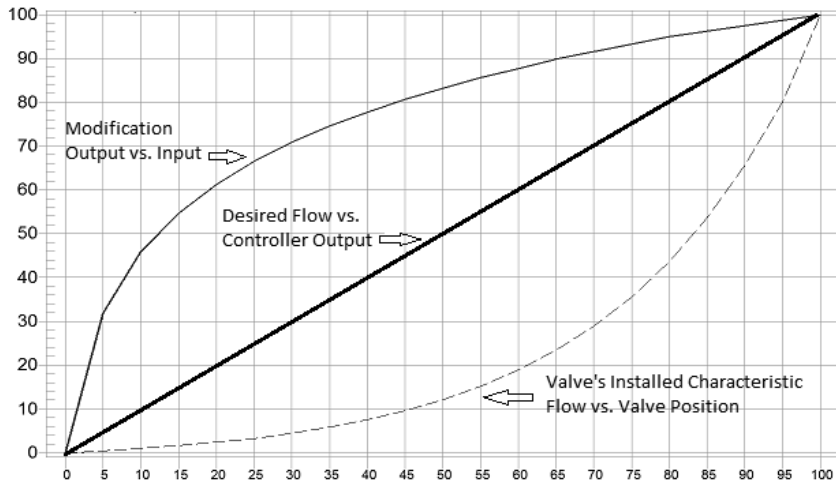

**Figure 2-12.** A valve with a nonlinear installed flow characteristic can have its characteristic modified to give a linear relationship between controller output and flow by programming a modification curve into the DCS output or a digital positioner.

Here, the valve's equal percentage installed characteristic is modified by programming a modification curve into either the DCS output or the input block of a digital positioner. This gives a linear relationship between the controller output and flow in the system. This resulting linear characteristic permits more aggressive tuning while maintaining stability throughout the flow range. We previously saw that the Neles "Nelprof" control valve sizing software can graph a control valve's installed characteristic. Neles also has software that is used to configure their digital positioner. This software can calculate the required linearizing modification curve and download it to a Neles digital positioner. Figure 2-12 is a screen shot from the flow modification software. There is also a simple manual method of coming up with a modification curve for one of the most common applications. This application is that you need to use a valve with a nonlinear inherent characteristic in a system that does not have very much pipe or other equipment that would linearize an equal percentage characteristic. For instance, you have a gravity flow system with very little pipe, but the flowing medium is pulp stock, so you would not be able to use a globe valve with linear trim. Your most likely choices would be a full ball, a segment ball or perhaps a high performance butterfly valve. These all have nonlinear inherent characteristics. Because you don't have much pipe, the installed characteristic will be pretty much the same as the inherent characteristic (nonlinear). From the valve manufacturer's catalog data, draw a plot of the valve's inherent flow characteristic. It will look something like the bottom trace in Figure 2-12, "Valve's Installed Characteristic, Flow vs. Valve Position." The horizontal axis should be valve position from zero to 100%. The vertical axis should be zero to 100% of the valve's rated  $C_v$ . Next, simply re-label the axes on the graph. The vertical axis becomes "Input to modification block" and the horizontal axis becomes "Output from modification block." Then program the points on the graph into the DCS output block or the positioner input block.

## Valve Sizing

Next we will discuss the importance of proper control valve sizing.

When we talk about "sizing a control valve" we usually mean the entire process of selecting the correct valve for the application, including checking for things like choked flow, cavitation, excessive noise and excessive flow velocity in the valve body. At this point we will only discuss the aspect of choosing the correct size, as the other aspects will be covered in later sections. If we don't select the right size valve, there are two possibilities: (1) The valve may be too small. If it is, we will know right away, because it won't be able to pass the required flow. In actual practice, under sized valves are fairly uncommon; (2) The valve may be too large, which turns out to be all too common. An oversized control valve will cost more than is necessary, although that is only a minor point compared to the real problem. The real problem with an oversized valve is that it will be very sensitive, that is small changes in valve position will cause large changes in flow. This will make it difficult or even impossible for it to adjust exactly to the required flow.

Figure 2-13 shows graphs of the *installed* characteristics of two different valves installed in the same system. These are both segment ball valves, which have equal percentage inherent characteristics, and the system has a lot of pipe. Note that up to the specified maximum flow rate of 550 gpm they both have reasonably linear installed characteristics.



lowers the vapor pressure line to the point that the vena contracta pressure must drop to in order for flow to choke.

The example in the lower left of the Figure 4-9 shows that for 193F water, the vena contracta pressure must drop to 94% of the upstream vapor pressure, or to 9.4 psi.

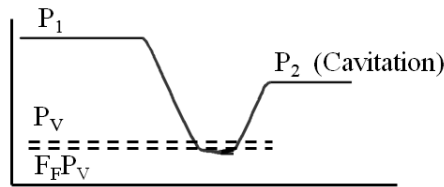

$$\Delta P_T = F_L^2 (P_1 - F_F P_V)$$

$P_1$  = Pressure upstream of valve

$P_V$  = Vapor pressure of liquid

$$F_F = 0.96 - 0.28 \sqrt{\frac{P_V}{P_C}} \quad (F_F \text{ will always be between } 0.68 \text{ and } 0.96)$$

( $F_F$ , Critical Pressure Ratio Factor)

|   |
|---|
| <b>Example</b>                            |
| For 193F water, $P_V = 10$ psia           |
| $F_F = 0.94$                              |
| So, $F_F P_V = 0.94 \times 10 = 9.4$ psia |

**Figure 4-9. Predicting choked flow.**

For the case shown in Figure 4-9, if the pressure drop ( $P_1 - P_2$ ) were held constant, but  $P_1$  were increased, the entire curve would move upward until the dip no longer touched the  $F_F P_V$  line and flow would no longer be choked. See Figure 4-10. Looking at the delta P sub T equation, you can see that when  $P_1$  increases, the terminal pressure drop also increases.

If we put  $P_1$  back where it originally was, then lowered the vapor pressure (by lowering the temperature of the liquid) the  $F_F P_V$  line on the graph would be lower down, and again, the pressure dip would no longer touch the  $F_F P_V$  line and flow would no longer be choked. See Figure 4-11. Again looking at the delta P sub T equation, you can see that when  $P_V$  decreases, the terminal pressure drop increases.

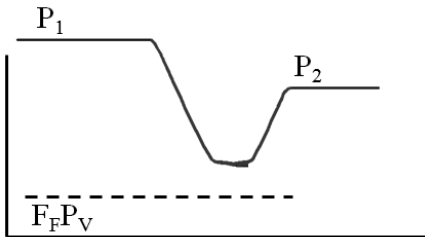

**Figure 4-10. Increasing  $P_1$  with constant  $\Delta P$ .**

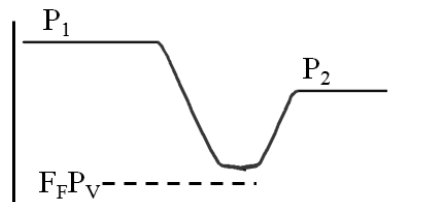

**Figure 4-11. Decreasing  $P_V$ .**

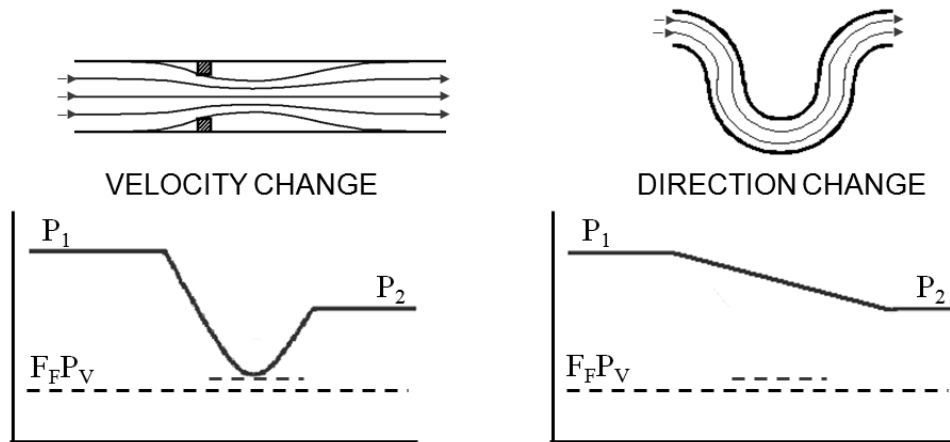

**Figure 4-14. Both velocity change and direction change cause permanent pressure loss.**

In a previous discussion, we talked about the flow passing through a restriction, where the increase in velocity causes a dip in pressure as some of the potential energy stored as pressure is converted to kinetic energy. When the area opens back up, kinetic energy is converted back to potential (pressure) energy. We also discussed that the turbulence caused by the throttling process causes some of the energy to be turned into heat energy, resulting in some permanent pressure loss. The overall pressure profile is as shown on the left of Figure 4-14.

Permanent pressure loss can also be caused when the flow direction is changed as shown on the right of Figure 4-14. Turbulence and friction is caused by the change in direction, and some of the energy is converted to heat energy. If the pressure loss is caused entirely by direction change, there is a permanent pressure loss without the dip that goes below  $P_2$  when there is a velocity increase as in the case of a restriction.

Figure 4-15 shows how permanent pressure loss is divided between velocity change and direction change depending on valve geometry.

In the more streamlined valves, like ball valves or segment valves (a segment valve is schematically shown in the left figure) most of the permanent pressure loss is caused by the velocity increase at the restriction, and very little of the permanent pressure loss is caused by direction change.

In the less streamlined valves, such as the globe valve shown in the right of Figure 4-15, part of the permanent pressure loss is caused by change of direction. This means that for the same amount of total permanent pressure loss a smaller percentage is caused by velocity increase, and as a result, for the same amount of permanent pressure loss, the pressure dip at the vena contracta will be smaller. Since smaller pressure dips are associated larger values of  $F_L$ , the less streamlined the valve, the larger the  $F_L$  will be.

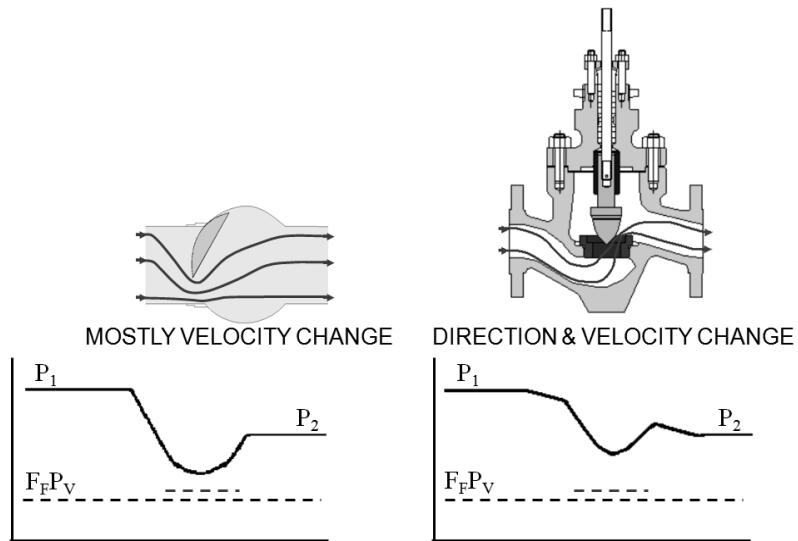

Figure 4-15. Pressure recovery and  $F_L$  depend on valve geometry. (Drawing at upper left courtesy of Metso Automation. Drawing at upper right courtesy of Koso Hammel Dahl.)

### Predicting and Preventing Cavitation

Let's take a look at an example where our task is to determine whether we will have a cavitation problem, and if so, look at some of the things we can do to eliminate the problem. For this discussion, refer to Figure 4-16.

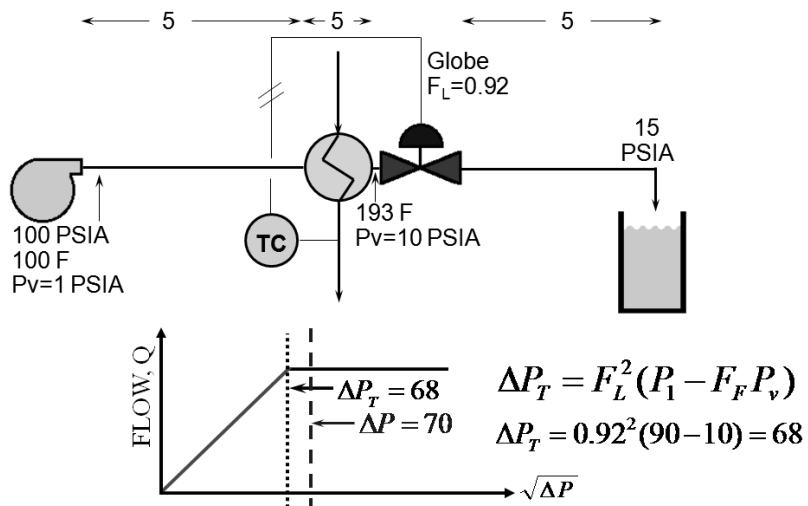
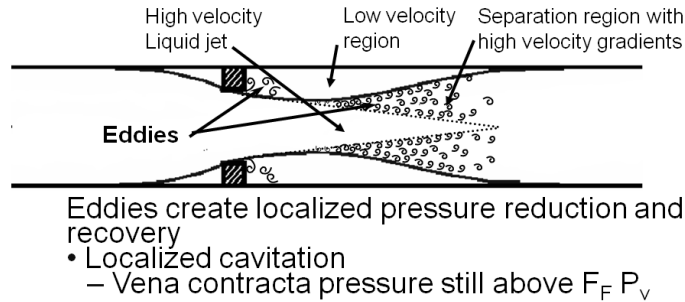

Figure 4-16. An exercise in determining whether cavitation will be a problem.



**Figure 4-25. Cavitation can begin when the vena contracta pressure is above  $F_F P_V$ .**

The first stages of cavitation begin when the average pressure in the main flow jet at the vena contracta is still above  $F_F$  times the vapor pressure of the liquid. (See Figure 4-25.) At points of abrupt increase of flow area the streamlines that are attached to the physical boundaries of the valve can separate and when they do, they form vortices or eddies. The rotational velocity in the eddies can be high enough that the local pressure inside an eddy drops below  $F_F P_V$  and vapor bubbles form. As the eddy's rotational velocity decreases, the pressure surrounding the vapor bubbles increases and the bubbles collapse.

Vortices also form in the shear layer adjacent to the main jet where high velocity gradients exist and these are also potential sources for cavitation.

This level of cavitation has the potential for generating noise and causing damage even before the flow curve starts to deviate from a straight line.

As the pressure drop across the valve is increased, the velocity at the vena contracta increases and finally the pressure at the vena contracta drops to  $F_F P_V$ . (See Figure 4-26.)

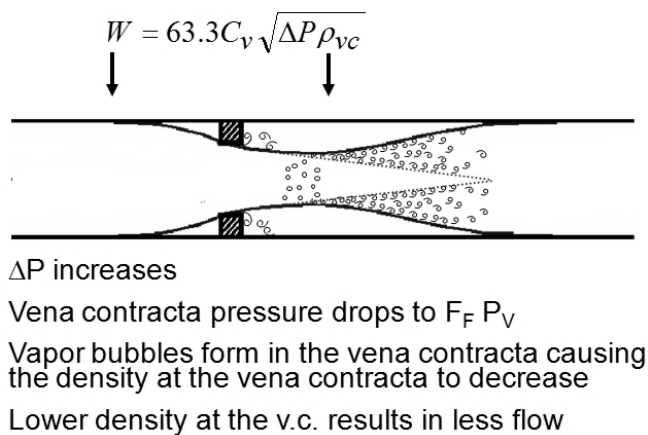

**Figure 4-26. Vena contracta pressure drops to  $F_F P_V$ .**

At first, the amount of vapor produced is small which results in a small reduction of the fluid density at the vena contracta. The reduction in density from that of a vapor

(which are incompressible) we don't need to make an issue of the fact, because the density at the vena contracta is exactly the same as the density upstream of the valve. Also, with liquids, the density at the vena contracta does not change as the flow rate changes so the only thing we have to consider is that flow (which could be either  $Q$  (for volumetric flow) or  $W$  (for mass flow) increases with pressure drop. With gas flow, the flow rate is proportional to the **pressure drop ratio,  $x$** , but because gas density changes with pressure, we also have to take into account the fact that flow is also proportional to the **density at the vena contracta**.

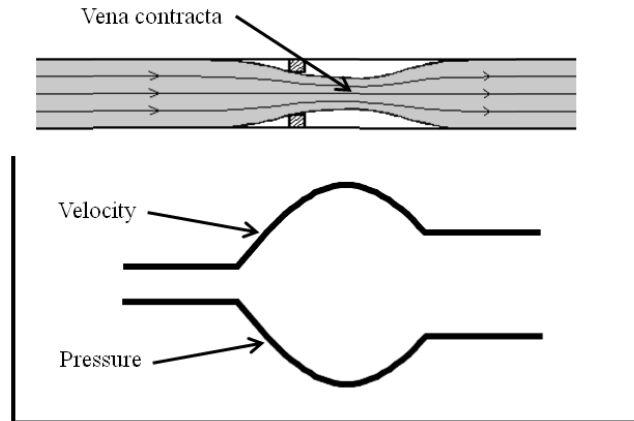

**Figure 5-9. Pressure and velocity profile inside a control valve. (The drawing at the top of the figure is used here and elsewhere in this chapter courtesy of Metso Automation.)**

The velocity of the gas flowing through a valve reaches a maximum at the vena contracta as shown in Figure 5-9.

Due to conservation of energy, as a result of the velocity increase, the pressure decreases to a minimum at the vena contracta. When the pressure decreases, the gas becomes less dense.

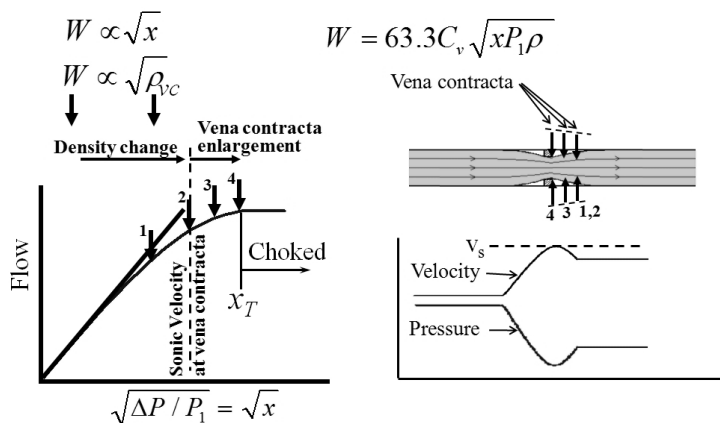

**Figure 5-10. Choking of flow as pressure drop ratio,  $x$ , increases, density at the vena contracta decreases and finally the vena contracta enlarges as it backs up to the physical restriction.**

does. Understanding this will help you understand why a sizing calculation may show that, with all the flow conditions the same, one style of valve will need a larger Cv than is required of a different style of valve.

### Ratio of Specific Heats Factor, $F_\gamma$

Before we conclude by showing how the ISA/IEC control valve sizing equations accurately predict both the shape of the gas flow vs. pressure drop ratio curve and the point at which flow chokes, we need to introduce one more concept, that of the “ratio of specific heats factor,”  $F_\gamma$ . The valve manufacturer’s published values of  $x_T$  are based on choked flow tests using air as the test medium. Many gasses other than air have sonic velocities that differ from that of air, so to compensate for the sonic velocity of those gasses, the published value of  $x_T$  is multiplied by the ratio of specific heats factor,  $F_\gamma$  (F sub gamma), of the gas for which the valve is being sized. The ratio of specific heats factor is calculated by dividing the ratio of specific heats,  $\gamma$ , of the flowing gas by the ratio of specific heats of air, which is 1.4.

$$F_\gamma = \gamma / 1.4$$

$F_\gamma$  of air reduces to 1.0.

Most tables of gas properties include values of the ratio of specific heats. Note that older versions of the ISA control valve sizing Standard, and some literature, use the symbol “k” for the Ratio of Specific Heats and  $F_k$  for the ratio of specific heats factor.

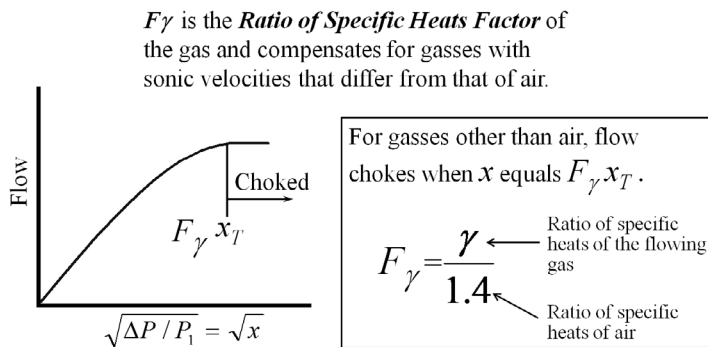

**Figure 5-13. Summary of the meaning and application of the ratio of specific heats factor,  $F_\gamma$ .**

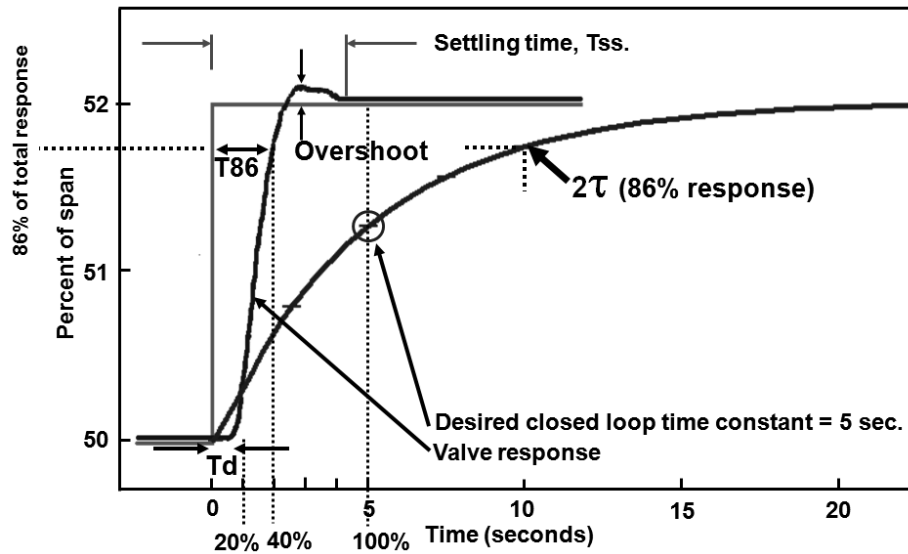

**Figure 6-11. Valve response compared with process requirement.**

Figure 6-11 is included to demonstrate why the recommended speed of response criteria make sense.

This is the same valve we looked at earlier, and it just meets the requirements for a process where the desired closed loop time constant is 5 seconds.

The dead time is just under the recommended 20% of the desired closed loop time constant. The dead time is over in time to have little impact on the overall process response.

The valve reaches 86% of its full travel after only 40% of the desired closed loop time constant. It can be seen that the valve is way ahead of when the process needs to reach 63% of its final value, and even farther ahead of when the process needs to reach its 2 time constants (86%) value. Because the valve reaches 86% of its total response in two seconds, and the desired process response should reach 86% of its total response in ten seconds, it is equivalent to saying that the valve is 5 times faster than the desired process response time.

At the early stage of the full response, a small overshoot will contribute very little, if anything, to an overshoot in the process.

The valve response has settled to its final value after slightly less than one desired process time constant, long before the process is expected to reach its final value.

### *Smart Digital Positioners Can Reduce Process Variability*

Shown in figure 6-12, as a reference point, is a standard mechanical analog electrical positioner.

At Point 4, if we were to draw a tangent to the installed characteristic graph, it would be parallel to the ideal linear graph, so at Point 4 the instantaneous gain is 1.0 and a corresponding Point 4 is placed on the installed gain graph at a gain of 1.0.

At Point 5 the tangent to the installed characteristic graph is not as steep as the ideal linear characteristic, so at Point 5, the instantaneous gain is less than 1.0 and a corresponding Point 5 is placed on the installed gain graph.

Typically, the installed characteristic and installed gain graphs of equal percentage valves in systems with a lot of pipe (the most common case) will have shapes similar to those in Figure 7-3, but sometimes not as symmetrical as shown here.

## Installed Gain Recommendations

Table 7-1 lists our recommendations (and the rules that Nelprof, the Neles control valve sizing and selection software, uses when selecting the best valve size for an application) for gain magnitude and variation.

### Within the specified control range:

1. Gain  $\geq 0.5$
2. Gain  $\leq 3.0$
3. Gain (max) / Gain (min)  $\leq 2.0$
4. As constant as possible
5. As close to 1.0 as possible

### Table 7-1. Installed gain recommendations.

Within the specified control range (by definition we will not be controlling outside this range so we are not concerned with what happens there), that is between  $q_{\min}$  and  $q_{\max}$ , the gain should not be less than 0.5, or greater than 3.0. (See the left hand graph in Figure 7-4 for a graphical representation of Criteria 1, 2 and 3.)

Going back to the definition of gain, that is the change in flow equals the change in valve position multiplied by the gain ( $\Delta q = \Delta h * \text{Gain}$ ), if the gain is too low, when the valve moves the flow hardly changes, which means the valve will not be effective in controlling flow. If the gain is too high, small errors in valve position will result in large errors in flow, making it difficult or impossible to control accurately.

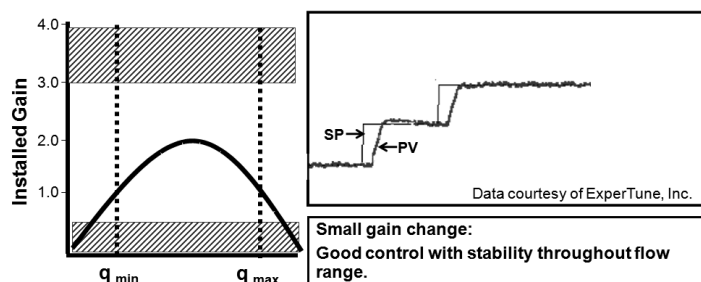
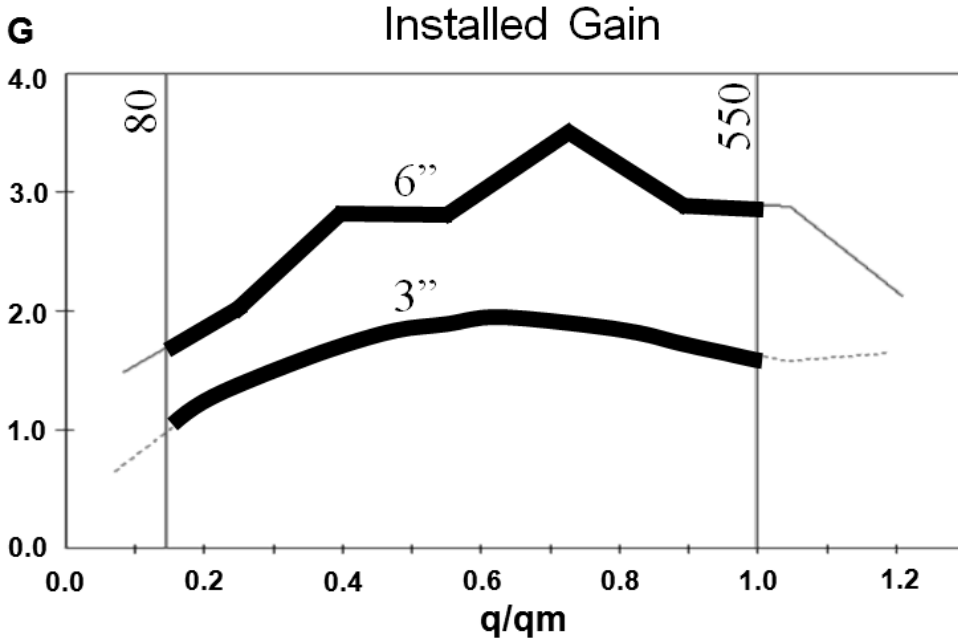

Figure 7-4. Left, gain criteria 1, 2, and 3 shown graphically. Right, system response when gain change is 2.0 or less.



higher installed gain. The installed flow characteristic graph is a good indicator of how linear the installed characteristic is, but not of how sensitive it is to changes in valve position.

The real story of how well a valve will control the process is in the installed gain graph. (See Figure 7-12.) The scaling of the horizontal axis is in units of  $q/q_m$  ( $q$  is actual flow and  $q_m$  is the maximum specified flow) which means that at  $q/q_m$  of 1 the flow is  $q_m$ , or 550 gpm. At 0.5 on the  $q/q_m$  scale the flow is 0.5 times 550 gpm, or 275 gpm.



**Figure 7-12. Installed gain of the six inch and three inch segment ball valves. Emphasis has been added to highlight the portions of the gain graphs that are within the specified flow range.**

Within the specified flow range of 80 to 550 gpm (between the two vertical lines) the gain of the 6 inch valve changes quite a bit. The more the gain changes, the harder it will be to find one good set of controller tuning parameters that will give both tight control and stable operation over the entire flow range. At about 70% of the maximum specified flow ( $q/q_m = 0.7$ ) the installed gain peaks at about 3.5. From our study of installed gain you will recall that when the gain is 3.5, a 1% position error will cause a 3.5% flow error. Ideally the gain should be as constant and as close to 1.0 as possible.

The installed gain of the 3 inch valve is much more constant than that of the 6 inch valve and is closer to the ideal 1.0. This will make it much easier to tune the loop for fast, but stable control throughout the specified flow range. The gain peak of 2 at  $q/q_m$  of about 0.6 means that a position error of 1% would give a flow error of 2% instead to the 3.5% error we would get with the 6 inch valve.

The Notes for the 6 inch valve were generated because the maximum gain is greater than 3.0, and the gain is changing within the specified flow range by more

Nelprof Version 6 draws the graphs, but the pipeline model it uses is based on the assumption that flow is turbulent. In many cases the graphs you get will be meaningful. The procedure is to do the calculations with the value of viscosity entered and note what percentage open the valve is. Then repeat the calculation, but with the viscosity deleted. If the percentage of valve opening at maximum flow changes by less than, say, 5 percentage points, you can assume that viscosity has minimal effect on the sizing calculation and you can assume that the graphs are reliable. If the percentage of valve opening changes by much more than 5 percentage points, viscosity does have a significant effect and the graphs will be less reliable. Typically, viscosities of over 100 centipoise can start having a noticeable effect.

The piping pressure drop calculations for two phase flow are very complex, and Nelprof does not attempt to draw graphs when you are using the two phase flow calculation.

### *Determining the Control Valve Pressure Drop*

When determining the control valve pressure drop to use in a control valve sizing calculation, there are two possible scenarios.

- When the system is existing or already designed.
- When you have a say in the system design.

The method for determining the pressure drop to use in the valve sizing calculation for an existing system, or one that has already been designed was illustrated and explained in the valve sizing example of this chapter.

### *Selecting a Pump for Optimum Control Valve Pressure Drop*

In this section we will use an analysis of control valve installed gain to help answer the question “What is the optimum control valve pressure drop to design into a system to ensure adequate control without using excessive pumping power?”

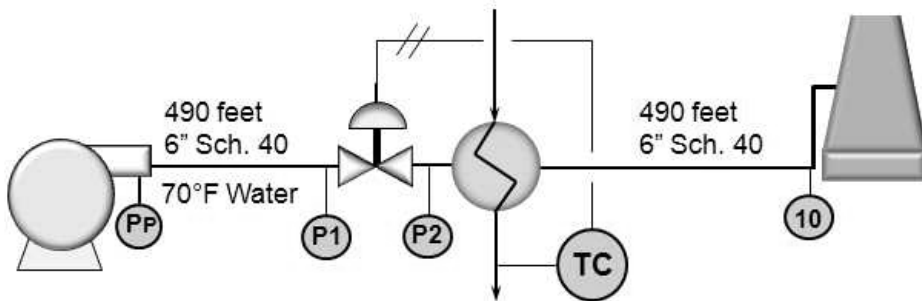

**Figure 7-15.** The control loop for which installed gain will be analyzed to select a pump that will result in optimum control valve pressure drop.

## ***Chapter 8: Control Valve Sizing***

As has been mentioned previously, selecting a properly sized control valve is essential to achieving the highest degree of process control. Now days the control valve sizing calculations are usually performed using a computer program. Most manufacturers of control valves offer control valve sizing software at no cost, though most are specific to that manufacture's valves only. One program that the author is familiar with, Metso's Nelprof, includes a number of generic valves to choose from. The generic choices include typical equal percentage globe valves, typical linear globe valves, typical ball valves, typical eccentric rotary plug valves, typical high performance butterfly vales and typical segment ball valves. These generic selections permit the user to investigate the applicability of different valve styles and sizes to a particular application, without showing a preference to a particular valve manufacturer. Also, the author has a set of comprehensive Excel spreadsheets that follow the methods of ANSI/ISA-75.01.01 (IEC 60534-2-1 Mod)-2007 *Flow Equations for Sizing Control Valves* that are available at no cost. These spreadsheets are applicable to the valves of all manufacturers.

This chapter presents a brief review of some of the subjects that must be considered to size and select the right control valve for a particular application. This is followed by step-by-step procedures that are suitable for **preliminary** calculations by hand, along with worked out examples. One could also use the procedures presented here to construct simple Excel spreadsheets for performing **preliminary** calculations.

### ***Selection of Control Valve Style***

The choice of control valve style (globe, ball, butterfly, etc.) is often based on tradition or plant preference. For example, a majority of the control valves in pulp and paper mills are usually ball or segmented ball valves. Petroleum refineries traditionally use a high percentage of globe valves, although the concern over fugitive emissions has started some users to look to rotary valves because it is often easier to obtain a long lasting stem seal with rotary valves. Globe valves offer the widest range of options for flow characteristic, pressure, temperature, noise and cavitation reduction. Globe valves also tend to be the most expensive. Segment ball valves tend to have a higher rangeability, and size for size, nearly twice the flow capacity of globe valves and in addition are less expensive than globe valves. On the other hand, segment ball valves are limited in availability for extremes of temperature and pressure and are more prone to noise and cavitation problems than are globe valves. High performance butterfly valves are even less expensive than ball valves, especially in larger sizes (say eight inch and larger). They also have less rangeability than the ball valves and are more prone to cavitation. The eccentric rotary plug valve (a generic term commonly applied to valves with trade names like Camflex<sup>®</sup>, a registered trademark of Dresser Masoneilan and Finetrol<sup>®</sup>, a registered trademark of Metso Automation) combines features of rotary valves, such as high cycle life stem seals and compact construction with the rugged construction of globe valves. Unlike the other rotary valves whose flow capacity is approximately double that of globe valves, the flow capacity of eccentric rotary plug

## ABOUT THE AUTHOR



**Jon F. Monsen, Ph.D., P.E.**, is a control valve technology specialist with more than 35 years of experience. He has lectured nationally and internationally on control valve application and sizing, and is the author of the chapter on “Computerized Control Valve Sizing” in the ISA Practical Guides book on Control Valves.

In this book, the author shares his expertise gained over the last 35 years of applying and selecting control valves for a broad range of applications. The material presented is based on the content of control valve application, selection and training seminars he has presented to a variety of control valve users. Topics include:

- How to properly size and select a control valve
- Selecting the right valve flow characteristic to match the process
- Control valve installed characteristics and installed gain
- How analysis of installed gain can aid in proper control valve selection
- Behavior of both gas flow and liquid flow in control valves, including noise reduction methods
- Prediction and reduction of cavitation damage in liquid applications
- Impact of the control valve on undesired process variability
- Valve performance recommendations



1941 Ringwood Ave.  
San Jose, California 95131  
Phone: 408.730.9850  
Fax: 408.730.1363  
[www.valin.com](http://www.valin.com)  
[www.valinonline.com](http://www.valinonline.com)